



Chapter

8.4



Ventilation

This chapter provides guidance for ventilation equipment including low or zero carbon sources (LZC), other (LZC) systems that follow the general principles of this chapter may also be acceptable, subject to specific agreement with NHBC.

This chapter contains the following sections:

- 8.4.1 Mechanical Ventilation and Heat Recovery system (MVHR)
- 8.4.2 Mechanical Extract Ventilation system (MEV)

For figure reference tables, please go to the end of each chapter.



Mechanical ventilation and heat recovery (MVHR)

MVHR (Mechanical Ventilation with Heat Recovery) systems provides fresh filtered air into a building whilst retaining most of the energy that has already been used in heating the air within the building see figure 1 & 2.

8.4.1.1	Compliance	01
8.4.1.2	Provision of information	02
8.4.1.3	System design	02
8.4.1.4	Acoustics	04
8.4.1.5	Building integration	04
8.4.1.6	Ductwork	05
8.4.1.7	Fixing and jointing of ductwork	05
8.4.1.8	Access and operation	06
8.4.1.9	Electrical installation requirements	06
8.4.1.10	Handling and storage	06
8.4.1.11	Commissioning and balancing	07
8.4.1.12	Sequence of work	07

For figure reference tables, please go to the end of each chapter.



Figure 1: MVHR schematic

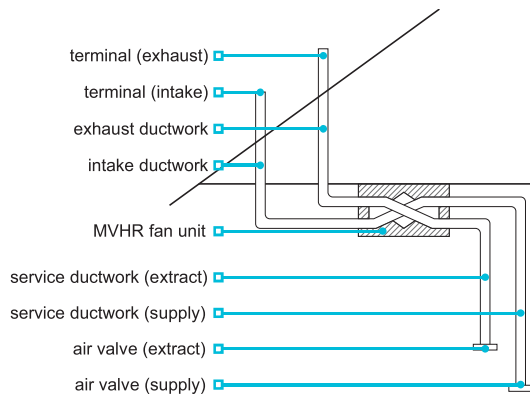
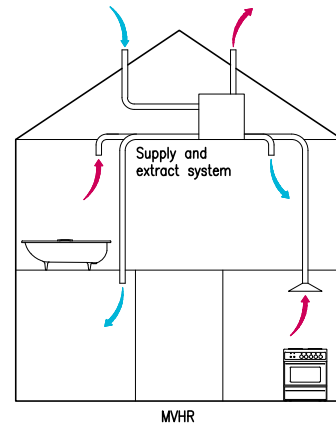

Figure 2: MVHR schematic layout



Definitions for MVHR

Air valve (extract and supply)	Wall or ceiling mounted fittings used to balance the flow rate of air between rooms; may be referred to as grilles or diffusers
Exhaust ductwork	Carries air from the fan unit and exhausts it to the external atmosphere
Intake ductwork	Carries air from the external atmosphere to the MVHR fan unit
MVHR fan unit	Unit that contains the fan(s), heat exchanger and filter(s)
Service ductwork extract and supply	Carries air between the air valves and the MVHR fan unit
Terminal fittings	Located on the outside of the building to finish the intake and exhaust ductwork

8.4.1.1 Compliance

Also see: Chapter 2.1

MVHR systems shall comply with the Technical Requirements. Issues to be taken into account include:

- 1) relevant standards
- 2) product certification
- 3) operative competency.

8.4.1.1.1 Relevant standards

Relevant standards include:

BS 476	'Fire tests on building materials and structures'
BS EN 1365-2	'Fire resistance tests for loadbearing elements. Floors and roofs'
BS EN 1366-3	'Fire resistance tests for service installations. Penetration seals'
BS EN 848-1, 2 & 5	Fans for general purposes, testing, noise and electrical safety
BS EN ISO 12001	Noise emitted by machinery and equipment
Approved Document F England	Ventilation
Technical handbook Scotland	Section 3 Ventilation
Technical Booklet NI	Part K Ventilation

8.4.1.1.2 Product certification

MVHR appliances should hold a current assessment by an appropriate independent technical approval's authority accepted by NHBC confirming compliance with UK CA, UK NI or CE marking:

- declaration of conformity detailing the standards the product complies with
- documents to be available on request.

8.4.1.1.3 Operative competency

MVHR systems should be installed by competent operatives:

- competent and familiar with the system being installed, installers who have been trained in accordance with the BPEC installers scheme would generally be acceptable to NHBC
- certified to a standard acceptable to NHBC.

8.4.1.2 Provision of information

Designs and specifications shall be produced in a clearly understandable format, include all relevant information and be distributed to the appropriate personnel.

Provision of information is important as it allows for energy efficient use of the building and common methods adopted to prevent overheating.

Clear and fully detailed drawings should be available on site to enable work to be carried out in accordance with the design. Designs should be issued to site supervisors, relevant specialist subcontractors and suppliers, and where used include the following information:

- fixing schedule
- a full set of current drawings
- indication of which manufacturer and/or installer is responsible for each system and interface
- commissioning schedule
- manufacturers' specifications
- interface details
- on-site testing requirements
- type and spacing of clips and fixings
- type and location of ancillary components, including those used for fire safety and acoustic purposes
- commissioning certificates
- location of all ductwork runs, the fan unit and controls
- type, size and position of ducts and terminals
- direction of fall for 'horizontal' ductwork
- designed airflow-balancing figures for the system
- thermal modelling.

8.4.1.3 System Design

MVHR systems shall be in accordance with relevant Building Regulations and designed to minimise disturbance caused by noise. Issues to be taken into account include:

- 1) location
- 2) system
- 3) compatibility
- 4) performance
- 5) air valve and terminals
- 6) control of condensation
- 7) protection from the cold.

8.4.1.3.1 Location

MVHR systems should be correctly located, including ancillary components, and should be located and identified in accordance with the manufacturer's recommendations.

8.4.1.3.2 System

MVHR systems should be in accordance with relevant Building Regulations and installed to ensure that effective ventilation is provided without affecting health or creating unnecessary noise.

8.4.1.3.3 Compatibility

The MVHR system should be designed as a complete package, taking into account the performance of all components and materials, to ensure compatibility and the performance requirements of the system.

Particular consideration should be given where components from different manufacturers are specified on the same system.

8.4.1.3.4 Performance

The MVHR system should be designed to provide satisfactory performance and be installed according to the design and manufacturer's recommendations. Variations from the design should maintain the satisfactory performance of the system and be approved by the designer.

Issues that should be taken into account include:

- ventilation rates as set out in appropriate Building Regulations and standards
- fan capacity, accounting for airflow resistance of the system
- ensuring the even distribution of airflow, taking into account regulations and standards airflow resistance, including from bends and fittings.

Airflow resistance should be calculated using figures for air valves and terminals determined in accordance with BS EN 13141-2 and data supplied by the duct manufacturer. Ductwork should be as direct as possible to reduce the number of bends.

Allowance should be made for air transfer within the home. Where gaps between the underside of internal doors and the floor finish are used for air transfer, the guidance in Chapter 9.1 'A consistent approach to finishes' should be considered.

8.4.1.3.5 Air valves and terminals

Air valves should be selected according to location and function, ensuring appropriate specification for:

- wall or ceiling location
- supply or extract function
- the velocity of the system.

To create cross-ventilation within a room and to ensure satisfactory operation, air valves on low velocity systems should be:

- positioned on the opposite side of the room from internal door openings
- a minimum of 200mm from walls, where located on a ceiling
- a maximum of 400mm from the ceiling, located on a wall
- a minimum of 600mm (on plan) from hobs in kitchens
- positioned to account for the likely location of tall furniture and to avoid draughts over beds and seating areas
- lockable, where adjustable.

To prevent cross-contamination, intake terminals should generally be separated from exhaust terminals and other potential sources of pollution by a minimum of 1m measured on plan. Increased separation distances may be required between the intake and any:

- soil and vent pipe terminal
- boiler flue outlet
- biomass or solid fuel chimney terminal.

Terminals should prevent the entry of birds and animals.

8.4.1.3.6 Control of condensation

Ductwork should be insulated to prevent condensation formation where:

- it passes through spaces outside the insulated parts of the home, such as a roof void
- carrying cold air through spaces that are within the insulated parts of the home.

This can be achieved by using suitable pre-insulated ductwork, or a proprietary insulation system with a thermal resistance equivalent to a minimum of 25mm of insulating material, with a thermal conductivity of 0.04W/Mk.

Ductwork insulation, including that used for proprietary duct insulation systems and pre-insulated ducts should be:

- inert, durable, and suitable for use with the ductwork system
- continuous and vapour resistant
- not adversely affected by moisture vapour
- installed in a neat and workmanlike manner to ensure that there are no gaps
- installed in accordance with the manufacturer's recommendations.

Where a vapour control layer is incorporated, the joints should be sealed using appropriate tapes or sealants as recommended by the manufacturer.

Table 1: Ductwork insulation

Type of duct	Ductwork continuously insulated	
	Ductwork located inside the insulated part of the home	Ductwork located outside the insulated part of the home
Intake	Yes	Yes
Exhaust	Yes	Yes
Service (supply and extract)	No	Yes ⁽¹⁾

Notes

¹ Additional insulation should be provided to protect the system from the cold.

Any condensate that forms within the fan unit or ductwork should be able to drain to a suitable outfall. Fan units should be located to enable connection of the condensate drain to the soil and waste system via a dry trap.

8.4.1.3.7 Protection from the cold

MVHR systems should be protected from the effects of cold. Issues to be taken into account include:

- performance in relation to indoor air quality
- the manufacturer’s recommendations where any parts are located outside the insulated part of the home
- insulation of ductwork and other system components.

Figure 3: Protection from the cold

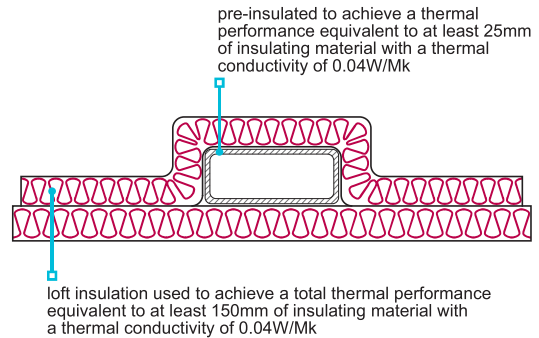

To prevent damage to the components and ensure satisfactory operation, MVHR systems should be fitted with automatic frost protection.

Horizontal sections of service ductwork, outside the insulated parts of the home, should be insulated to achieve a thermal resistance equivalent to at least 150mm of insulating material with a thermal conductivity of 0.04W/Mk. This may be achieved by installing the ductwork between the layers of horizontal insulation. See figure 3.

Condensate drains located outside the insulated part of the home should be insulated to prevent freezing.

8.4.1.4 Acoustics

MVHR systems shall be designed to minimise disturbance caused by noise.

MVHR fan units should be sized to run at their optimum speed and to provide suitable performance whilst taking the resulting noise and vibration into account. Specifying MVHR fan units that can provide the required airflow rates when running at less than full speed can reduce unnecessary noise.

Ductwork should be sized to allow air to pass freely without causing excessive noise disturbance. To reduce noise transfer along ductwork, a short length of flexible duct can be installed adjacent to air valves and fan units. Other issues to be taken into account include:

- noise between habitable rooms
- external noise
- location of the MVHR fan unit
- the type of mountings used to secure the MVHR fan unit.

8.4.1.5 Building integration

Also see: Chapter 7.1, 7.2 and 8.6

MVHR systems shall be securely fixed and not adversely affect the weather resistance of the building. Issues to be taken into account include:

- 1) weather tightness
- 2) fixing of fan units
- 3) fire-stopping.

8.4.1.5.1 Weather tightness

Proprietary roof terminals should be used to ensure the weathertightness of the roof covering.

8.4.1.5.2 Fixing of fan units

MVHR fan units should only be fixed to parts of the building capable of taking the load. Where MVHR fan units are supported by framed structures, additional components such as noggins may be required to provide a secure fixing point.

Fan units should be located, orientated, and fixed in accordance with the design, using the clips, brackets and fixings recommended by the manufacturer.

8.4.1.5.3 Fire-stopping

The MVHR system should not adversely affect the fire performance of the building. Issues to be taken into account include:

- ensuring that the fire requirements of the building are in accordance with relevant Building Regulations
- suitable detailing of components passing through other elements of the building
- location and type of firestops to be used
- integrity of protected stairs and halls
- integrity of walls and floors.

Proprietary passive fire protection components should be suitably tested and specified to take account of the test conditions.

8.4.1.6 Ductwork

Also see: Chapter 8.4.2.7

Ductwork design and the materials used should be suitable for the intended purpose and not adversely affect the performance of the building. MVHR ductwork and insulation should be installed to a satisfactory standard.

Where ductwork routes require alterations to structural elements, these should be in accordance with the manufacturer's recommendations or in accordance with Technical Requirement R5.

Ductwork should:

- provide satisfactory performance for the life of the system
- be routed as directly as practicable
- be of a rigid or semi-rigid material suitable for use in MVHR systems see figure 4
- be fixed in accordance with the manufacturer's recommendations.

Bends, connections and junctions should be formed using proprietary components that are part of the ductwork system.

Flexible ducting should:

- only be located adjacent to fan units or air valves
- not be more than 300mm in length
- not be used to form bends.

Figure 4: Air valve and ductwork

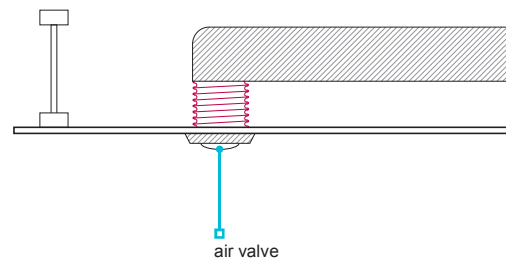

8.4.1.7 Fixing and jointing of ductwork

MVHR ductwork and insulation shall be installed to a satisfactory standard. Issues to be taken into account include:

- 1) fixing
- 2) jointing.

Ductwork should be installed in a neat and workmanlike manner.

8.4.1.7.1 Fixing

To prevent condensate collecting, horizontal ductwork should be to a suitable outfall in accordance with the design and installed to a true line to avoid localised dips. Where parallel ductwork is run it should be positioned to maintain an even gap.

Where ductwork passes through an external wall, it should be positioned to slope slightly downwards to prevent water entering the building.

Ductwork should be securely held in position by evenly spaced clips no more than 750mm apart, or in accordance with the ductwork manufacturer's recommendations.

Ductwork should not be in direct contact with other surfaces, such as plasterboard ceilings, that may transfer noise to the home.

8.4.1.7.2 Jointing of ductwork

The method and materials used for jointing ductwork should be specified by the duct manufacturer, and be:

- durable and airtight
- securely fixed
- sealed with purpose-designed connections in accordance with the manufacturer's recommendations.

Where tapes and sealants are used, they should be suitable for the intended purpose and be recommended by the ductwork manufacturer. Issues to be taken into account in relation to the durability of the joining method include:

- thermal movement
- moisture
- temperature
- compatibility with the duct material.

Tape should be installed in a neat and workmanlike manner, and surfaces should be dry and free from grease and dust before applying. Excess sealant should not extrude to the inside of the duct.

8.4.1.8 Access and operation

MVHR systems shall be designed and installed to ensure that the fan unit and associated controls are easily accessible for the purposes of cleaning, inspection, maintenance, and repair or replacement.

Safe access should be provided to MVHR systems, including switchgear, and controls. This is to enable the cleaning, inspection, maintenance and repair of systems. Access should be provided in accordance with the manufacturer’s recommendations.

Where plant is to be installed in a loft or roof void additional guidance is provided in chapter 7.2.12.

Table 2: Guidance for the suitable functioning of, and access to, the MVHR system

	Fan unit located inside the insulated part of the home	Fan unit located outside the insulated part of the home
Access	Access should not be obstructed and panels should be located and sized to enable routine servicing to be carried out	A safe means of access, including a suitable walkway and a working platform 1m ² immediately adjacent to the MVHR fan unit, should be provided. The walkway and platform should be designed to ensure the continuity of any insulation, and the supporting structure should be designed to take account of the additional load
Control and functionality	Where a ‘boost’ function is provided, it should switch off automatically and be located in, or adjacent to, the room it serves. Where a ‘summer bypass’ function is provided, it should operate automatically and divert the airflow around the heat exchanger. The MVHR system should be capable of being isolated by a switched fused spur	
Indication and controls	MVHR systems should include visual indicators showing maintenance and servicing requirements, and mode of operation. These should be visible from within the insulated envelope, not obscured from view, and be simple to use	
Cleaning	To maintain operating performance, extract service ductwork and air valves should either be fitted with filters, or ductwork should be accessible for cleaning	

8.4.1.9 Electrical installation requirements

Also see: Chapter: 8.1.6

The electrical installation shall be in accordance with relevant regulations.

Electrical installations should comply with BS 7671 ‘Requirements for Electrical Installations’.

The electrical installation should be capable of being isolated from all other electrical sources when required, for maintenance or testing.

The inclusion of any lightning protection must be installed as directed by the equipment manufacturer. Also see 8.1.6.15.

8.4.1.10 Handling and storage

Materials, products, and systems shall be handled, stored and protected in a satisfactory manner to prevent damage, distortion, weathering and degradation.

MVHR systems should be:

- transported, lifted, handled and stored in accordance with the manufacturer’s recommendations
- delivered in sequence to avoid storage
- protected to avoid the risk of damage.

To ensure performance, MVHR systems and ancillary components should be installed in a logical and timely sequence in accordance with the manufacturer’s recommendations.

8.4.1.11 Commissioning and balancing

MVHR design, materials and sitework shall be tested and commissioned in accordance with the commissioning schedule.

Upon completion of the installation MVHR systems should be protected from dust during the construction of the home. Where possible the system should be switched off and dust covers applied to air valves.

Prior to completion of the home, the system:

- including ductwork and filters, should be checked to ensure it is clear from dirt and dust that may have accumulated during construction
- should be commissioned to confirm performance
- should be adjusted by using the air valves and controls to achieve the correct balancing and airflow rates
- should have air valves locked in position after correct commissioning and balancing.

Where the system cannot be balanced using the air valves and system controls, the complete system should be checked to ensure that it complies with the design.

Any changes from the design should be referred to the designer. Adjusting the fan speed above the designed output may result in noise disturbance and should be avoided.

A copy of the commissioning certificate should be made available to NHBC upon request.

8.4.1.12 Sequence of work

MVHR systems shall be installed in accordance with a suitable schedule.

To ensure performance, MVHR systems and ancillary components should be installed in a logical and timely sequence in accordance with the manufacturer's recommendations.

Figure reference table

Figure reference table 8.4.1			
Fig No	Title/Description	Clause	Page
Figure 1	MVHR schematic	8.4.1	1
Figure 2	MVHR schematic layout	8.4.1	1
Figure 3	Protection from the cold	8.4.1.3.7	4
Figure 4	Air valve and ductwork	8.4.1.6	5

Mechanical extract ventilation systems (MEV)

Bathroom and kitchen extract fans providing decentralised extract ventilation (dMEV) or central mechanical extract ventilation (cMEV) and may be continuous or intermittent depending on design and location.

8.4.2.1	Compliance	09
8.4.2.2	Provision of information	10
8.4.2.3	System design	10
8.4.2.4	Acoustics	12
8.4.2.5	Building integration	12
8.4.2.6	Ductwork	13
8.4.2.7	Fixing and jointing of ductwork	13
8.4.2.8	Access and operation	14
8.4.2.9	Electrical installation requirements	14
8.4.2.10	Handling and storage	14
8.4.2.11	Commissioning and balancing	14
8.4.2.12	Sequence of work	14

For figure reference tables, please go to the end of each chapter.



Figure 1: dMEV layout

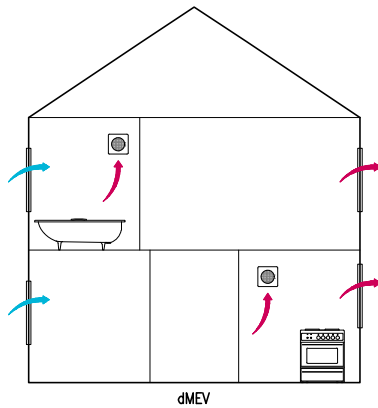
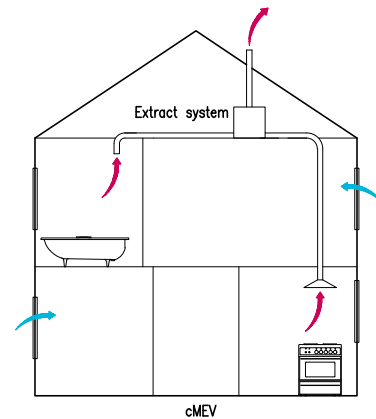

Figure 2: cMEV layout



Definitions for MEV

Air valve (extract)	Wall or ceiling mounted fittings used to balance the flow rate of air between rooms; may be referred to as grilles
cMEV	Continuous mechanical extract ventilation system providing simultaneous ventilation to reduce excess moisture using multipoint extraction points
dMEV	Mechanical extract ventilation system providing ventilation to reduce excess moisture using single extraction point
Exhaust ductwork	Carries air from the fan unit and exhausts it to the external atmosphere
MEV	Relates to a generic term relating to both cMEV and dMEV
Service ductwork extract	Carries air between the air valves and the MVHR fan unit
Terminal fittings	Located on the outside of the building to finish the intake and exhaust ductwork

8.4.2.1 Compliance

Also see: Chapter 2.1

MEV design, materials and sitework shall comply with the Technical Requirements, issues to be taken into account include:

- 1) relevant standards
- 2) product certification
- 3) operative competency.

8.4.2.1.1 Relevant standards

Relevant standards include:

BS 476	'Fire tests on building materials and structures'
BS EN 1365-2	'Fire resistance tests for loadbearing elements. Floors and roofs'
BS EN 1366-3	'Fire resistance tests for service installations. Penetration seals'
BS EN 848-1, 2 & 5	Fans for general purposes, testing, noise and electrical safety
BS EN ISO 12001	Noise emitted by machinery and equipment
Approved Document F England	Ventilation
Technical handbook Scotland	Section 3 Ventilation
Technical Booklet NI	Part K Ventillation

8.4.2.1.2 Product certification

MEV appliances should hold a current assessment by an appropriate independent technical approvals authority accepted by NHBC confirming compliance with UK CA, UK NI or CE marking:

- declaration of conformity detailing the standards the product complies with
- documents to be available on request.

8.4.2.1.3 Operative competency

MEV systems should be installed by competent operatives:

- competent and familiar with the system being installed, and or
- certified to a standard acceptable to NHBC.

8.4.2.2 Provision of information

Designs and specifications shall be produced in a clearly understandable format, include all relevant information and be distributed to the appropriate personnel.

Provision of information is important as it allows for energy efficient use of the building and common methods adopted to prevent overheating.

Clear and fully detailed drawings should be available on site to enable work to be carried out in accordance with the design. Designs should be issued to site supervisors, relevant specialist subcontractors and suppliers, and where used include the following information:

- fixing schedule
- a full set of current drawings
- indication of which manufacturer and/or installer is responsible for each system and interface
- commissioning schedule
- manufacturers' specifications
- interface details
- on-site testing requirements
- type and spacing of clips and fixings
- type and location of ancillary components, including those used for fire safety and acoustic purposes
- commissioning certificates
- location of all ductwork runs, the fan unit and controls
- type, size and position of ducts and terminals
- direction of fall for 'horizontal' ductwork
- designed airflow-balancing figures for the system
- thermal modelling.

8.4.2.3 System Design

MEV systems shall be designed to minimise disturbance caused by noise. Issues to be taken into account include:

- 1) location
- 2) system
- 3) compatibility
- 4) performance
- 5) control of condensation
- 6) terminals.

8.4.2.3.1 Location

MEV systems should be correctly located, including ancillary components, in accordance with the manufacturer's recommendations. The route of ductwork should take account of other building elements. Ductwork passing through structural elements should not adversely affect the structural or fire performance of the building. Where alterations to structural elements, such as I-joists, are required, this should only be carried out in accordance with the manufacturer's recommendations or be designed by an engineer in accordance with Technical Requirement R5.

The fire requirements of the building should be in accordance with relevant Building Regulations and standards. Issues that should be taken into account include:

- suitable detailing of components passing through other elements of the building
- the location and type of dampers and firestops to be used
- the integrity of protected stairs and halls
- the integrity of walls and floors.

8.4.2.3.2 System

MEV systems should be in accordance with relevant Building Regulations and installed to ensure that effective ventilation is provided without affecting health or creating unnecessary noise.

8.4.2.3.3 Compatibility

MEV systems should ensure compatibility with other building elements and not adversely affect the performance of the building.

The MEV system should be designed as a complete package, taking into account the performance of all components and materials, to ensure compatibility and the performance requirements of the system.

Particular consideration should be given where components from different manufacturers are specified on the same system.

8.4.2.3.4 Performance

The MEV system should be designed to provide satisfactory performance and be installed according to the design and manufacturer's recommendations. Variations from the design should maintain the satisfactory performance of the system and be approved by the designer.

Issues that should be taken into account include:

- ventilation rates as set out in appropriate Building Regulations and standards
- fan capacity, accounting for airflow resistance of the system
- ensuring the even distribution of airflow, taking into account regulations and standards airflow resistance, including from bends and fittings
- airflow resistance should be calculated using figures for air valves and terminals determined in accordance with BS EN 13141-2 and data supplied by the duct manufacturer. Ductwork should be as direct as possible to reduce the number of bends.

Allowance should be made for air transfer within the home. Where gaps between the underside of internal doors and the floor finish are used for air transfer, the guidance in Chapter 9.1 'A consistent approach to finishes' should be considered.

8.4.2.3.5 Control of condensation

Where extract ductwork passes through unheated spaces, it should be continuously insulated to achieve a thermal resistance equivalent to a minimum of 25mm of insulating material with a thermal conductivity of 0.04W/(mK). This can be achieved by using:

- suitable pre-insulated ductwork, or
- a proprietary insulation system. See figure 3.

Alternatively, the ductwork can be fitted with a condensate trap that discharges to the outside or installing the duct to slope to the outside. See figure 4.

Figure 3: Ventilation control condensation - insulation

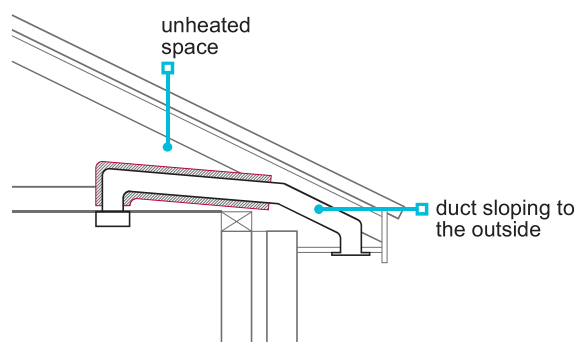
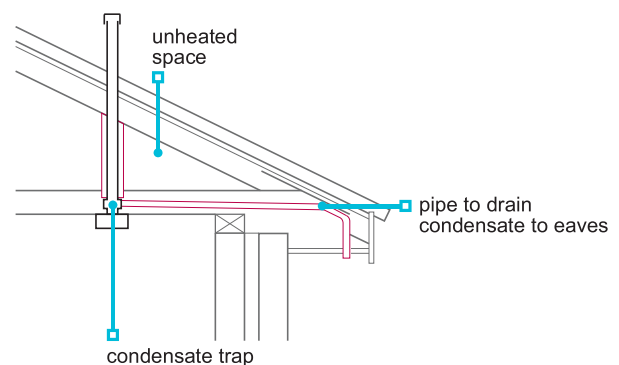

Figure 4: Ventilation control condensation - condensate trap



8.4.2.3.6 Terminals

Ventilation systems should terminate freely to open air.

The air flow resistance of terminals should not adversely affect the performance of the ventilation system. Airflow resistance of terminals can be obtained through testing in accordance with BS EN 13141-2. See figure 5.

Figure 5: Termination to ventilation systems

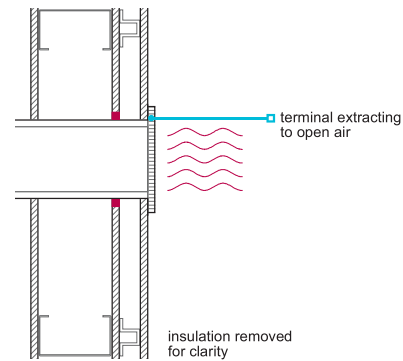

8.4.2.4 Acoustics

MEV systems shall be designed to minimise disturbance caused by noise.

MEV fan units should be sized to run at their optimum speed and to provide suitable performance whilst taking the resulting noise and vibration into account. Specifying MEV fan units that can provide the required airflow rates when running at less than full speed can reduce unnecessary noise.

Ductwork should be sized to allow air to pass freely without causing excessive noise disturbance. To reduce noise transfer along ductwork, a short length of flexible duct can be installed adjacent to air valves and fan units. Other issues to be taken into account include:

- noise between habitable rooms
- external noise
- location of the MEV fan unit
- the type of mountings used to secure the MEV fan unit.

8.4.2.5 Building integration

Chapter 7.1, 7.2 and 8.6

MEV design, materials and sitework shall comply with the Technical Requirements, Issues to be taken into account include:

- 1) weathertightness
- 2) fixing of fan units
- 3) fire-stopping.

8.4.2.5.1 Weathertightness

Proprietary roof terminals should be used to ensure the weathertightness of the roof covering.

8.4.2.5.2 Fixing of fan units

MEV fan units should only be fixed to parts of the building capable of taking the load. Where MEV fan units are supported by framed structures, additional components such as noggings may be required to provide a secure fixing point.

Fan units should be located, orientated, and fixed in accordance with the design, using the clips, brackets and fixings recommended by the manufacturer.

The type, size, number, position and fitting tolerance of fixings should be in accordance with the manufacturer's recommendations.

8.4.2.5.3 Fire-stopping

The MEV system should not adversely affect the fire performance of the building. Issues to be taken into account include:

- ensuring that the fire requirements of the building are in accordance with relevant Building Regulations
- suitable detailing of components passing through other elements of the building
- location and type of firestops to be used
- integrity of protected stairs and halls
- integrity of walls and floors.

Proprietary fire components should be suitably tested, and specified to take account of the test conditions.

8.4.2.6 Ductwork

Also see: Chapter 8.4.1.6

Ductwork to intermittent and continuously running mechanical extract ventilation systems shall ensure satisfactory performance and durability. Issues to be taken into account include:

- 1) resistance to airflow
- 2) installation of ductwork.

8.4.2.6.1 Resistance to airflow

Ductwork systems should be designed to minimise the resistance to airflow and be formed from compatible components.

Rigid duct is preferable to flexible, but where flexible duct is used, it should be restricted in length to ensure that the airflow resistance does not prevent the designed ventilation rate from being achieved. Flexible duct should be installed:

- straight
- in accordance with the manufacturer's recommendations.

Bends should generally be formed with proprietary rigid components. Where flexible duct is used to form bends on an intermittent extract system, they should be restricted to a maximum of:

- two for systems up to 30 L/s
- one for extract rates higher than 30 L/s.

8.4.2.6.2 Installation of ductwork

Ductwork should be installed in a neat and workmanlike manner, be securely fixed, and have:

- adequate support throughout its length
- sealed mechanically fixed joints and connections.

Where ductwork passes through an external wall, it should be positioned to slope slightly outwards to prevent water entering the building. Clips and supports for ductwork should be spaced at equal distances and in accordance with the ductwork manufacturer's recommendations. For rigid ductwork, they should not generally be more than 750mm apart.

Ductwork should not be in direct contact with other surfaces, such as plasterboard ceilings, that may transfer noise to the home.

It is not necessary to provide non-return shutters on extract fans or cooker hoods or their ducting unless specifically required by the manufacturer's installation instructions.

8.4.2.7 Fixing and jointing of ductwork

MEV ductwork and insulation shall be installed to a satisfactory standard. Issues to be taken into account include:

- 1) fixing
- 2) jointing.

Ductwork should be installed in a neat and workmanlike manner.

8.4.2.7.1 Fixing

To prevent condensate collecting, horizontal ductwork should be to a suitable outfall in accordance with the design and installed to a true line to avoid localised dips. Where parallel ductwork is run it should be positioned to maintain an even gap.

Where ductwork passes through an external wall, it should be positioned to slope slightly downwards to prevent water entering the building.

Ductwork should be securely held in position by evenly spaced clips no more than 750mm apart, or in accordance with the ductwork manufacturer's recommendations.

Ductwork should not be in direct contact with other surfaces, such as plasterboard ceilings, that may transfer noise to the home.

8.4.2.7.2 Jointing of ductwork

The method and materials used for jointing ductwork should be specified by the duct manufacturer, and be:

- durable and airtight
- securely fixed
- sealed with purpose-designed connections in accordance with the manufacturer's recommendations.

Where tapes and sealants are used, they should be suitable for the intended purpose and be recommended by the ductwork manufacturer. Issues to be taken into account in relation to the durability of the jointing method include:

- thermal movement
- moisture
- temperature
- compatibility with the duct material.

Tape should be installed in a neat and workmanlike manner, and surfaces should be dry and free from grease and dust before applying. Excess sealant should not extrude to the inside of the duct.

8.4.2.8 Access and operation

MEV systems shall be designed and installed to ensure that the fan unit and associated controls are easily accessible for the purposes of cleaning, inspection, maintenance, and repair or replacement.

Safe access should be provided to MEV systems including switchgear and controls. This is to enable the cleaning, inspection, maintenance and repair of systems. Access should be provided in accordance with the manufacturer's recommendations.

Where plant is to be installed in a loft or roof void guidance is provided in chapter 7.2.12.

8.4.2.9 Electrical installation requirements

Also see: Chapter: 8.1.6

The electrical installation shall be in accordance with relevant regulations.

Electrical installations should comply with BS 7671 'Requirements for Electrical Installations'.

The electrical installation should be capable of being isolated from all other electrical sources when required, for maintenance or testing.

The inclusion of any lightning protection must be installed as directed by the equipment manufacturer. Also see 8.1.6.15.

8.4.2.10 Handling and storage

Materials, products, and systems shall be handled, stored and protected in a satisfactory manner to prevent damage, distortion, weathering and degradation.

MEV systems should be:

- transported, lifted, handled and stored in accordance with the manufacturer's recommendations
- delivered in sequence to avoid storage
- protected to avoid the risk of damage.

8.4.2.11 Commissioning and balancing

MEV design, materials and sitework shall be tested and commissioned in accordance with the commissioning schedule.

Upon completion of the installation MEV systems should be protected from dust during the construction of the home. Where possible the system should be switched off and dust covers applied to air valves.

8.4.2.12 Sequence of work

MEV systems shall be installed in accordance with a suitable schedule.

To ensure performance, MEV systems and ancillary components should be installed in a logical and timely sequence in accordance with the manufacturer's recommendations.

Figure reference table

Figure reference table 8.4.2			
Fig No	Title/Description	Clause	Page
Figure 1	dMEV layout	8.4.2	9
Figure 2	cMEV layout	8.4.2	9
Figure 3	Ventilation control condensation - insulation	8.4.2.3.5	12
Figure 4	Ventilation control condensation - condense trap	8.4.2.3.5	12
Figure 5	Termination to ventilation systems	8.4.2.3.6	12